

Installation Instructions

JFlaps®

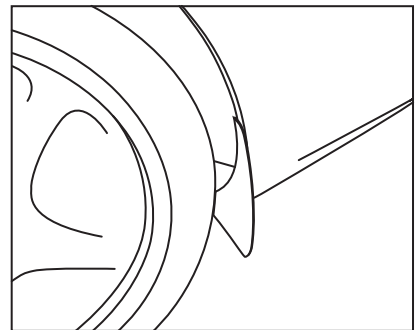
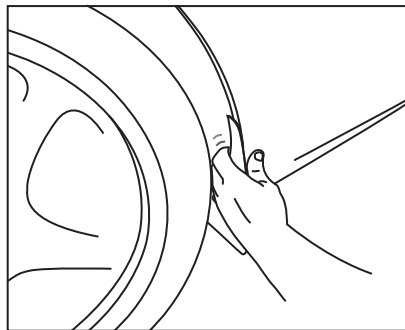
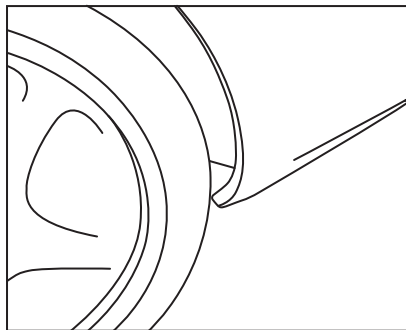
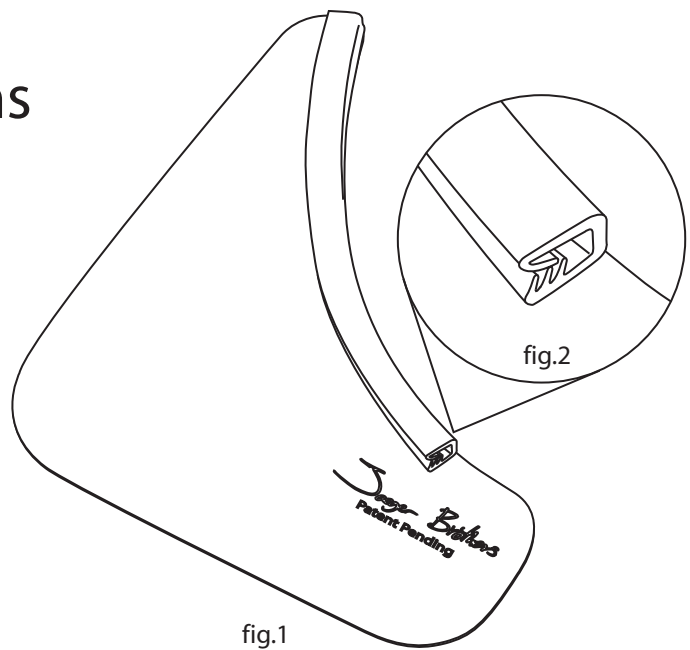

Be sure that the JFlaps (fig.1) and the fender edge (fig.3) where they will be mounted, are clean and dry.

Beginning at the bottom of the JFlap, position the u channel (fig.2) over the fender edge and carefully push it on along its entire length (fig.4). After checking for good alignment on the vehicle, push firmly along the u channels entire length for secure fit.

If the u channel feels as though it fits too tightly or loosely the width of the u channel may be adjusted by hand, by removing the JFlap and gently widening or squeezing the u channel for better fit.

Removal: Beginning at the bottom of the JFlap, gently pull the u channel off the fender flange.

Clean the JFlaps using mild soap and water, rinse and dry thoroughly.

For more information please visit: jflaps.com

Supplement for 2005 - 2009 Mustang Front Jflaps

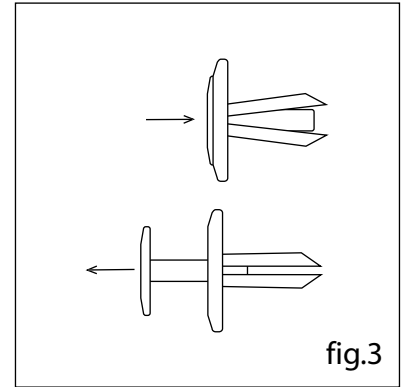
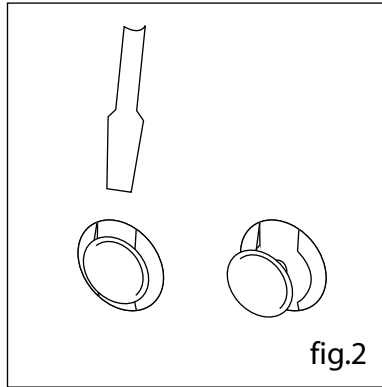
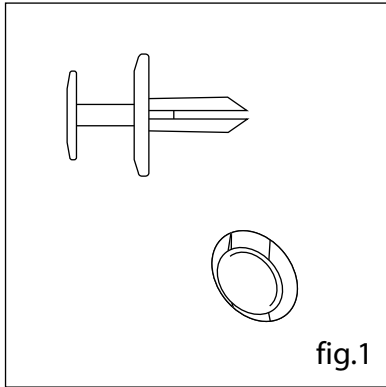

The Mustang uses expanding fasteners (fig.1) in the front wheel well to attach the rocker trim (fig.4), they must be removed and then reinstalled once the front flaps are in place.

Insert a small flat tool (fig.2) in the recess located on the perimeter of the fastener and twist, the center of the fastener (fig.3) should lift easily and then allow the entire fastener to be removed.

Install the flap as described in the Jflaps installation instructions, then insert the fastener through the hole and press the center of the fastener (fig.3) to expand it.

The finished appearance should be like this. (fig.5)

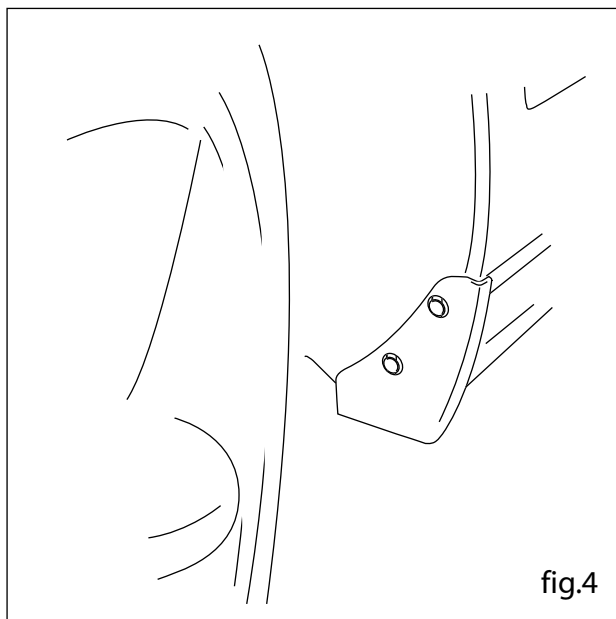

stock appearance

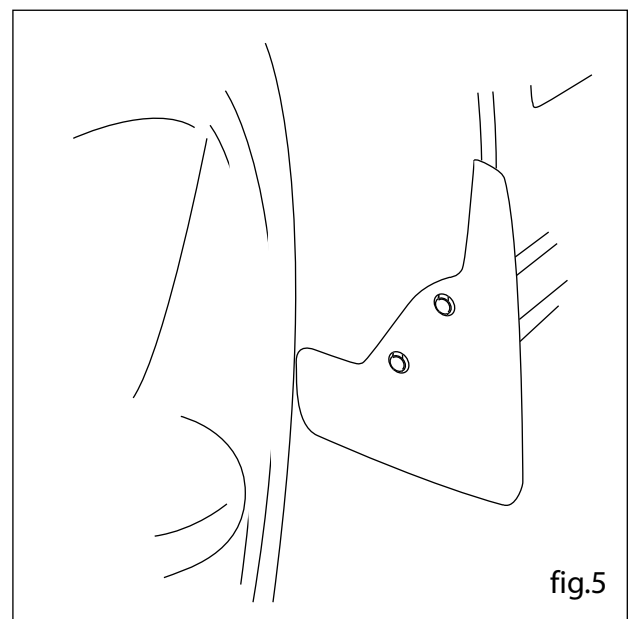

with Jflap installed